

PART NAME	FIBERGLASS NEMA BOX	PART No.	NF-6610, 6611, 6612, 6613, 6614	REVISION DATE	-
-----------	---------------------	----------	---------------------------------	---------------	---

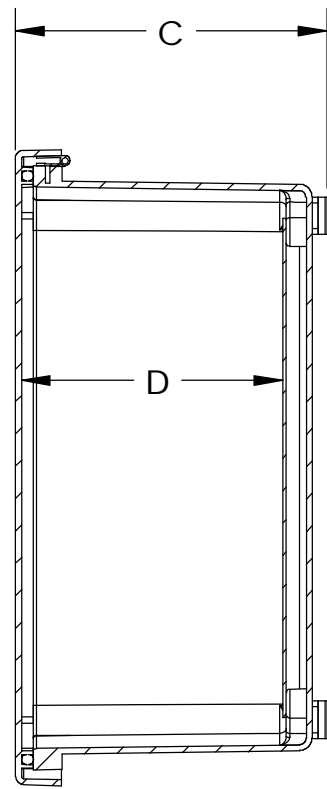

SECTION A-A

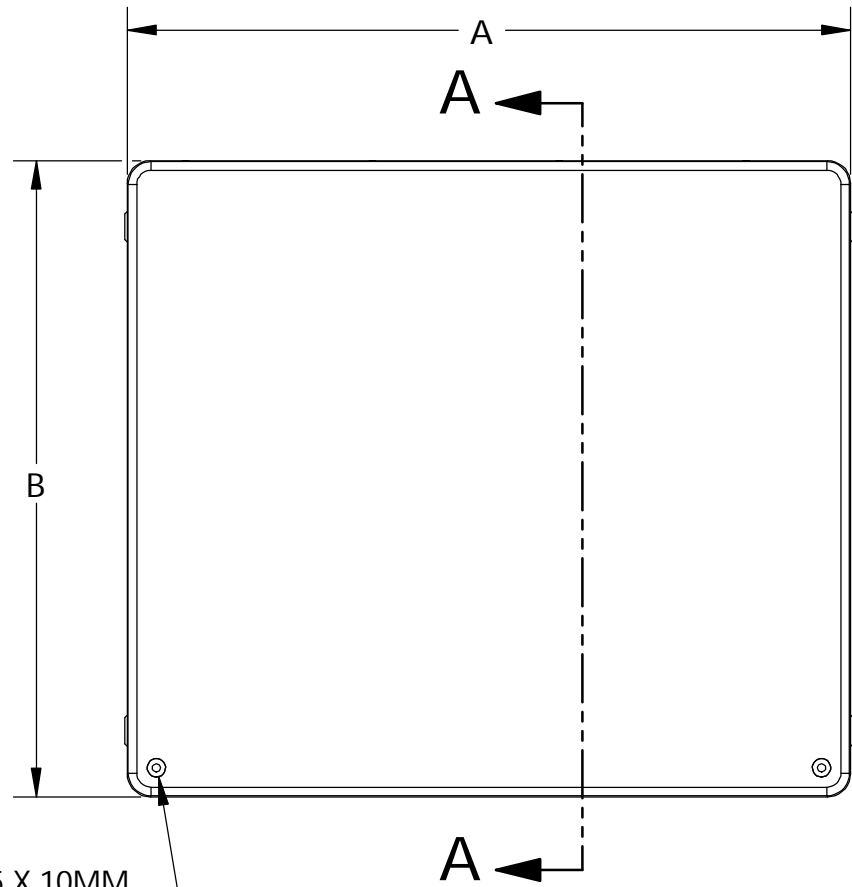
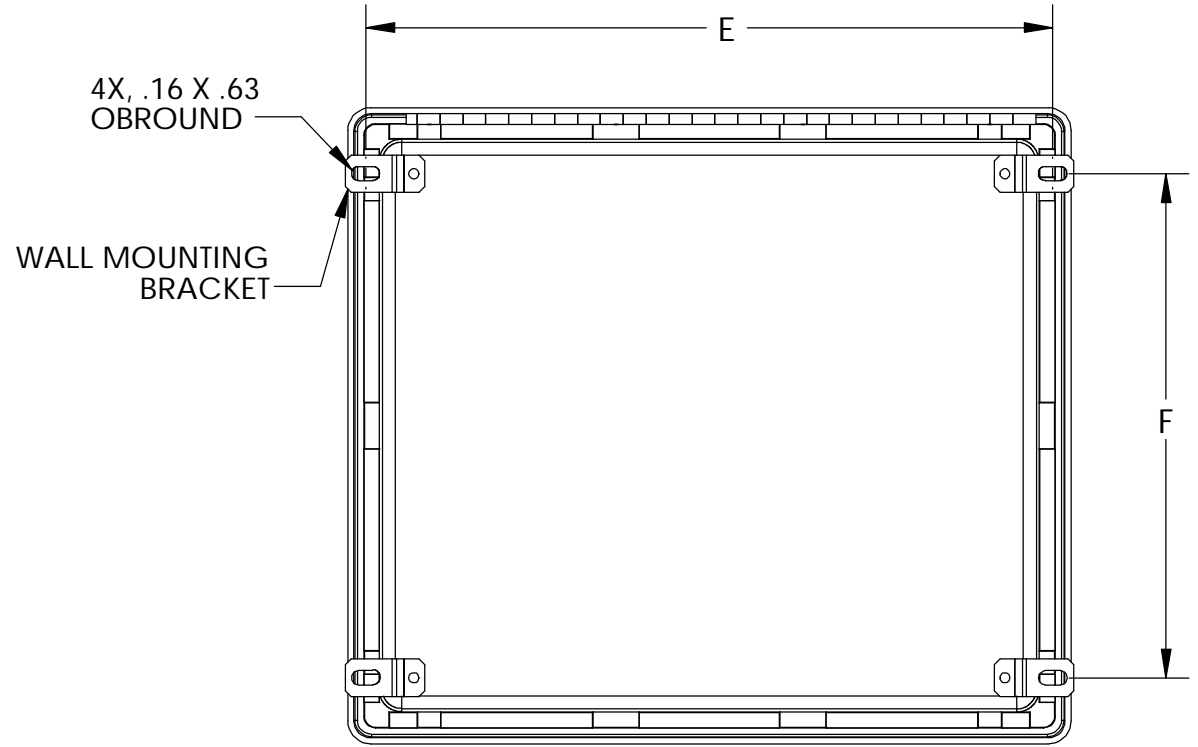

2X, M5 X 10MM CAPTIVE SCREW

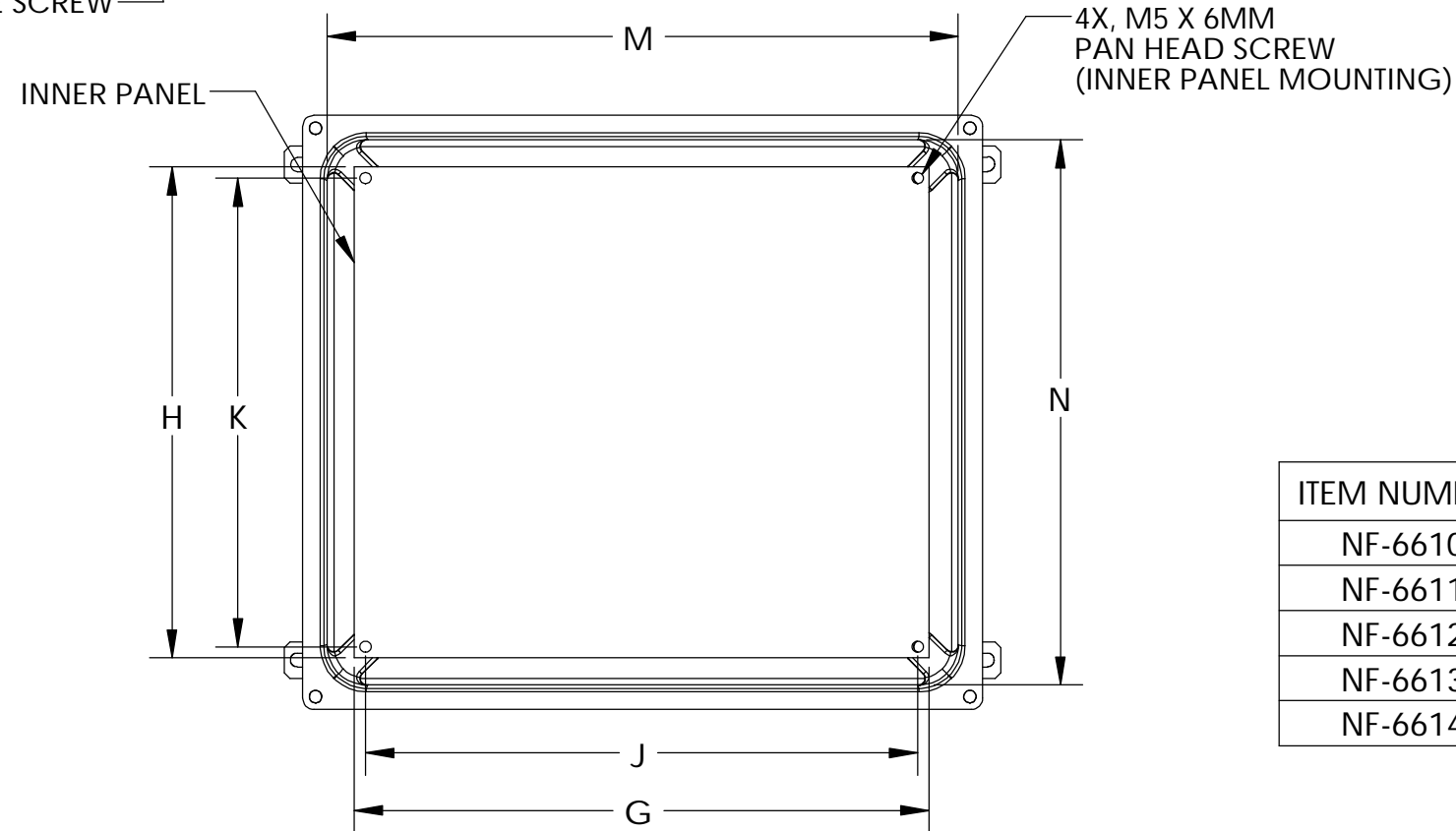

MATERIAL:
 BODY & COVER - 30% FIBERGLASS REINFORCED POLYESTER
 PANEL - 14 GA. [.078" (2mm) THK.] COLD ROLLED STEEL
 MOUNTING BRACKETS AND HARDWARE - 14 GA. [.078" (2mm)] STAINLESS STEEL
 CONTINUOUS HINGE - 18 GA. [.050" [1.3mm] THK.) STAINLESS STEEL
 GASKET - NEOPRENE

FINISH:
 BODY & COVER - LIGHT GRAY
 PANEL - LIGHT GRAY POLYESTER POWDER COAT PAINT
 MOUNTING BRACKETS & HINGE - NATURAL

ITEM NUMBER	A	B	C	D	E	F	G	H	J	K	M	N
NF-6610	7.75	7.75	4.80	3.70	6.95	4.88	4.75	4.75	4.25	4.25	6.10	6.10
NF-6611	9.64	7.75	4.80	3.70	8.86	4.88	6.75	4.75	6.25	4.25	8.10	6.10
NF-6612	11.78	9.90	6.80	5.70	11.00	7.00	8.75	6.90	8.25	6.40	10.10	8.30
NF-6613	13.78	11.90	6.80	5.70	13.00	9.00	10.75	8.90	10.25	8.40	12.10	10.30
NF-6614	15.78	13.90	6.80	5.70	15.00	11.00	12.75	10.90	12.25	10.40	14.10	12.30